

PZM-30D

Fig. 3

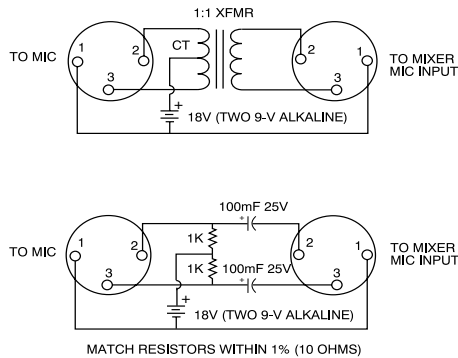

If your mixer or recorder requires an unbalanced phone plug connector, modify the cable leaving the power supply as follows: Solder the cable shield and the pin-3 lead to the phone-plug ground terminal. Solder the pin-2 lead to the phone plug "hot" or "tip" terminal.

Placement

PZMs are designed to operate on any stiff non-absorbent boundary (or surface). Typical boundaries are a floor, wall, ceiling, or table. This type of mounting improves the low-frequency response.

The published response curve is measured on an "infinite" boundary such as a floor, ceiling or wall. The microphone's low-frequency response depends on the size of the boundary on which it is placed. Specifically, the response begins to shelve down at and below the frequency F , where $F = 750/D$ and D = the boundary dimension in feet. At approximately $F = 188/D$,

the output of the microphone is down 6 dB, becomes omnidirectional, and maintains a flat response down to approximately 30 Hz.

Several placement examples are described in the **Crown Boundary Mic Application Guide**, which may be obtained from your dealer or by writing directly to Crown.

Architects' and Engineers' Specifications

The microphone shall be the Crown PZM-30D or equivalent. The microphone shall have a hemispherical pattern (when used on an infinite boundary). The element shall be a subminiature electret type of rugged construction. A smooth frequency response from 20 Hz to 20 kHz shall be obtained. The response shall be switch-selectable between flat (F) or rising (R).

The microphone shall employ the patented PRP principle for maintaining phase coherency, thus eliminating comb filtering in the audible spectrum.

The PZM-30D shall have a sensitivity of -43 dBV/Pa. The microphone shall accept 150 dB SPL input while contributing no greater than 3% THD (open circuit termination). Equivalent noise shall be typically 20 dBA re .0002 dyne/cm². The microphone color shall be black. The microphone connector shall be a male 3-pin XLR-type. The Crown PZM-30D is specified.

Warranty

Crown professional microphones are guaranteed unconditionally against malfunction from any cause for a period of three years from date of original purchase. Please refer to the enclosed full warranty statement for more detail.

Service

If the microphone does not function properly, replace or repair mic cables, replace the battery or check the power supply.

If you determine the microphone product(s) is defective, return the complete product in its original packaging to: **Crown Service Department, Plant 2SW, 1718 W. Mishawaka Road, Elkhart, IN 46517**. For further assistance or technical support call **(800) 342-6939**.

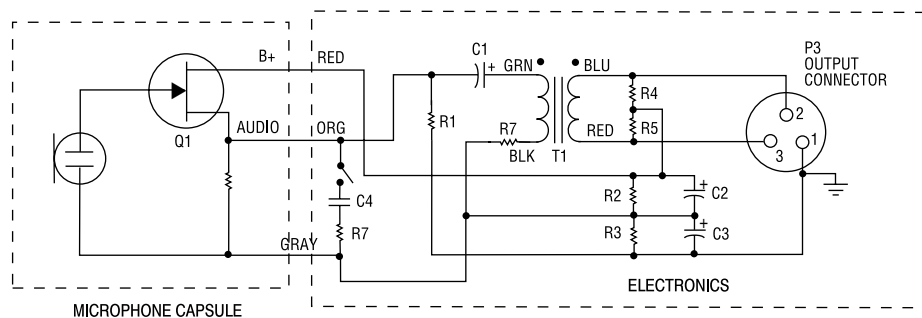

PZM-30D Schematic



Crown International, Inc.
P.O. Box 1000
Elkhart, IN 46515-1000
TEL: 219-294-8000
FAX: 219-294-8FAX

©2000 Crown International, Inc. Crown®, PZM® and Pressure Zone Microphone® are registered trademarks of Crown International, Inc. Pressure Recording Process™ is a trademark of E.M. Long Associates. Specifications subject to change without prior notice.

PZM-30D

PRESSURE ZONE MICROPHONE®

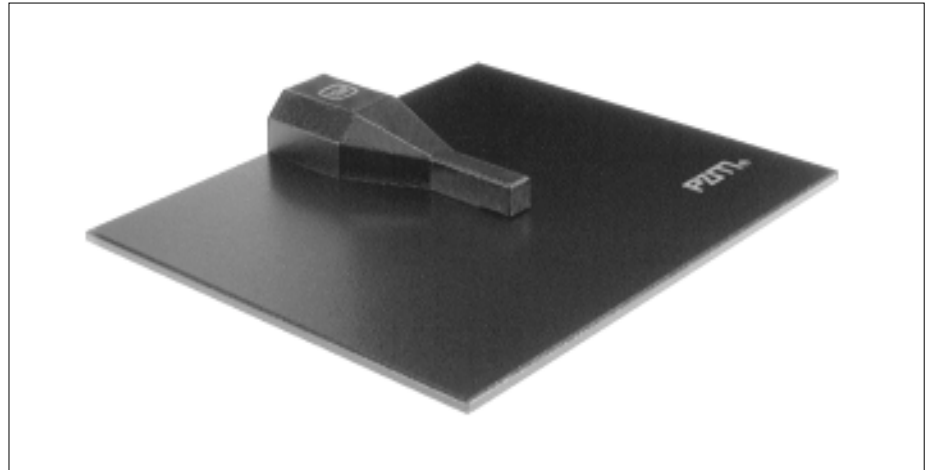

The PZM-30D is a Pressure Zone Microphone® designed for professional recording, sound reinforcement and broadcasting. It has many applications, from miking full orchestras or individual musical instruments to security or teleconferencing.

The PZM-30D has a switchable dual frequency response: rising (R) or flat (F). The “rising” position adds brilliance. This makes it useful wherever a crisp attack is desired, such as on percussion, drums, or piano. The user can get a bright sound without boosting high frequencies on the recording console; the result is lower noise. The “flat” position provides a smooth, flat, high-frequency response for natural sound reproduction.

These sturdy microphones are especially reliable because they can be used with a rugged detachable cable. The output is a male 3-pin XLR-type, balanced and low impedance, which permits long cable runs without hum pickup or high-frequency loss.

Like other Pressure Zone Microphones, the PZM-30D™ utilizes the Pressure Recording Process in which a miniature condenser microphone capsule is positioned very close to a sound-reflecting plate or boundary. The capsule is mounted in the “Pressure Zone” just above the boundary, a region where sound coming directly from the sound source combines in phase with sound reflected off the boundary. The benefits are a wide, smooth frequency response free of phase interference, excellent clarity and “reach,” a hemispherical polar pattern, and uncolored off-axis response.

Operating Instructions

The PZM-30D features self-contained electronics which allows it to plug directly into a standard 12-48 VDC phantom power supply.

Crown makes an AC-powered model PH-4B supply for powering up to four PZMs. Also available is a single-channel AC/battery supply, Crown model PH-1A. For special applications, you can make your own battery supply as suggested in Fig. 3 on the reverse side.

Using two-conductor shielded microphone cable, plug the microphone into a phantom power supply. Connect the power supply output to a mixer mic input, or if your mixer has phantom power built in, simply plug the PZM directly into a mixer mic input.

Specifications

Type: Pressure Zone Microphone.

Transducer: Electret condenser.

Frequency response: 20 Hz to 20 kHz. See Fig. 1.

Polar pattern: Hemispherical when used on a floor, wall or ceiling.

Open circuit sensitivity: 7 mV/Pa* (-43 dB re 1 volt/Pa).

Power sensitivity: -43 dB re 1 mW/Pa. EIA sensitivity -135 dBm.

Impedance: 240 ohms, balanced. Recommended minimum load impedance 1000 ohms.

Self-noise: 20 dB equivalent sound pressure level, A-weighted.

S/N ratio: 74 dB at 94 dB SPL.

Maximum Sound Pressure Level: 150 dB SPL at the microphone produces 3% THD.

Polarity: Positive pressure on the diaphragm produces positive voltage on pin 2 with respect to pin 3 of the output connector.

Operating voltage: Phantom power, 12 to 48 volts DC, positive voltage on pins 2 and 3 with respect to pin 1 of the output connector.

Current drain: 1.1 mA.

Connector: Male 3-pin XLR-type.

Cable: None supplied; use 2-conductor shielded microphone cable.

Switch: Frequency-response select switch for rising or flat response.

Color: Black.

Weight: 6.5 ounces (184 grams).

Dimensions: 6-in. x 5-in. x .75-in. (15.2 cm x 12.7 cm x 1.9 cm). See Fig. 2.

Included accessories: PZM windscreen, carrying pouch.

Optional accessories: PH-4B phantom power supply (4 channels, AC powered). PH-1A phantom power supply (1 channel, battery or AC-adaptor powered).

Fig. 1

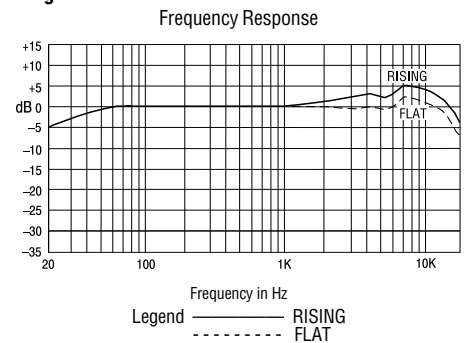

Low-frequency response depends on size of surface.

Fig. 2

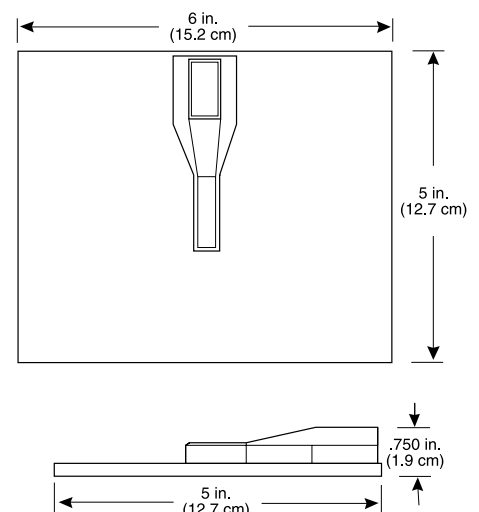

*1 pascal = 10 dynes/cm² = 10 microbars = 94 dB SPL.